

# Installation Instructions

## Joint System: 101-A01/A02

Note: Verify that the structural gap and blockout dimensions are in conformance with submittal data before beginning installation. If this is a Fire Rated Assembly, the fire barrier must be installed before the Architectural Joint System. Refer to the fire barrier instructions for specific system installation.

Fig. 1 (101-A01 Floor to Floor shown)

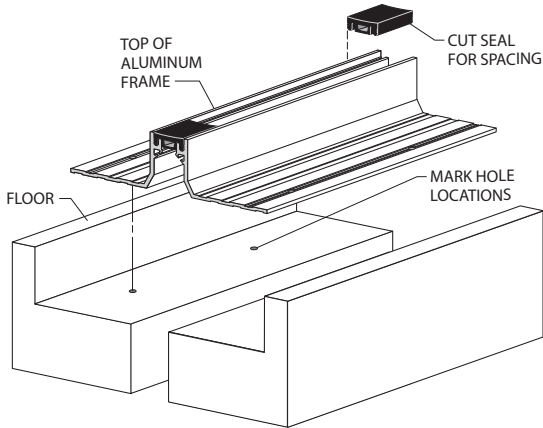

Fig. 1a. (101-A02 Floor to Wall shown)

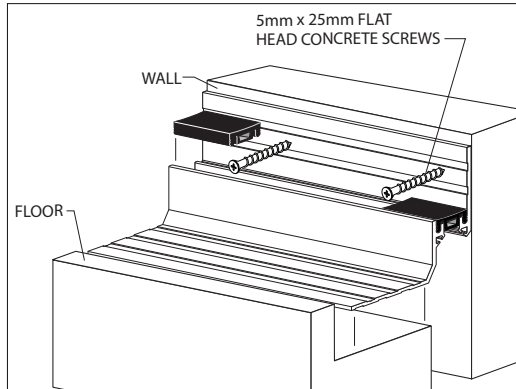
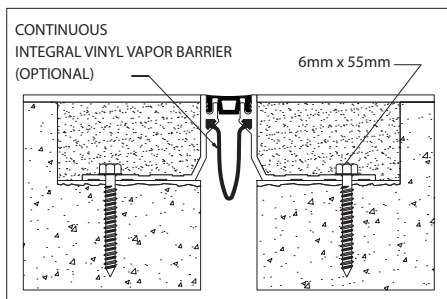

Fig. 1b.



1. Install the architectural joint system on a level surface within the blockout. To determine blockout depth, deduct thickness of floor finish from frame height. Make sure top of frame is level with the finished floor height. This may require adding leveling compound to raise the tops of the frames.

Figure 1

2. Cut the aluminum frames to the desired length.
3. To properly space frames, cut three small 2" [50mm] sections of seal. Insert one at each end and one in the center of each set of frames.
4. Center the frames over the structural gap, ensuring the frame bases do not extend over the gap.
  - 4a. For floor to wall system, make sure aluminum wall frame is firmly located against the finished wall. The top of the precut spacer should be level with the height of the finished floor (see Figure 1a).
5. Mark the pre-drilled hole locations on the substrate.
6. Remove the frame assembly from the blockout(s).
7. Drill holes in the blockout using a 3/16" (5mm) concrete drill bit to 23/8" (60mm) depth. Drill holes on the wall using a 1/4" (6mm) drill bit to a 11/8" (30mm) depth and insert plastic plug anchors.
  - 7a. Optional Integral Vapor Barrier: Starting at one end of the frame assembly, slide vapor barrier into dart receptacles (see Figure 1b).

IPC.801/REV.2

JOINTMASTER® Expansion Joint Systems

inpro.com • 800.222.5556 • 262.679.9010

World Headquarters S80 W18766 Apollo Drive, Muskego, WI 53150 USA

Installation Hotline: 866.394.6776

**inpro**®

# Installation Instructions

Joint System: 101-A01/A02

Fig. 2

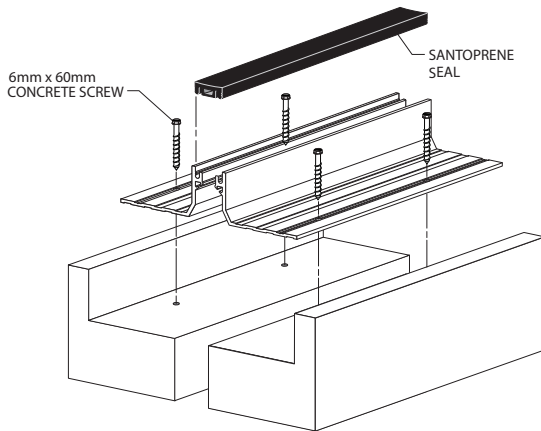

Fig. 2a.

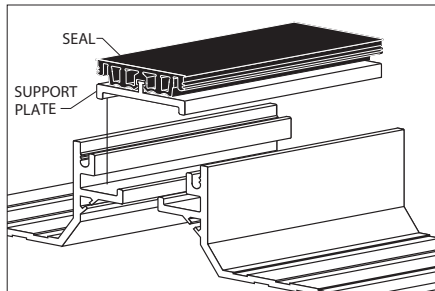

Fig. 3 (101-A01 Floor to Floor completed installation)

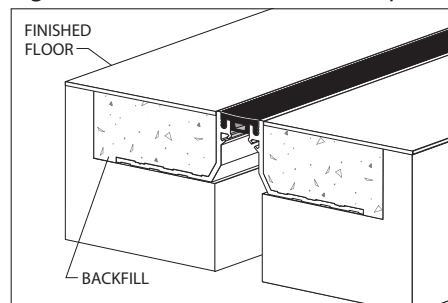

Figure 2

8. Return the frames into position over the drilled hole locations. Secure the floor frames in place with JK001 1/4" Tapcon concrete screws. Secure the wall frame in place using JK050 #10 x 1" flat head screws. Remove the temporary spacers.

9. Insert the Santoprene seal into the recessed frame slots until the seal is flush with the tops of the frames. NOTE: To assist in installing the seal, apply a mist of soapy water solution to the back of the seal. A 1" [25mm] wide seam roller may be used to fully engage the seal ears into the frame slots

9a. For the 1" [25mm] system, press the seal securely into the frame slots.

9b. For the 2" [50mm] and 3" [75mm] systems, make sure the seal is first inserted into the support plate. Then, center the seal and aluminum support plate assembly over the frames' support legs (see Figure 2a).

Figure 3

10. Backfill the blockout and install the floor finish level to the top of the frame. Clean the exposed surfaces with a non-solvent cleaner, such as 409, as required.